

MECATOME T215

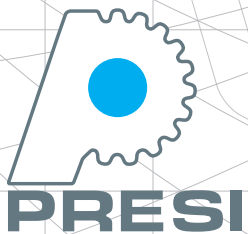

CUTTING

MECATOME T215
Ref. 51460



MECATOME T215

AUTOMATIC MICRO-CUTTING MACHINE

Robust and compact, the MECATOME T215 is an automatic micro-cutting machine. Its three programmable motorized axes make it a machine that adapts to all situations. The MECATOME T215 offers numerous work parameters that allow to optimize the cutting of the most complex parts.

Robustness

- Mechanically welded steel cover and PETG protective glass
- Stainless steel cutting chamber
- Epoxy paint

Intuitive control

- Programmable color touch screen
- Visualization of motor load
- Calculation of anti-rust concentration adjustment
- 3-axis joystick with 2 programmable control buttons

10L recirculating tank

- Double filtration system: mechanical & magnetic
- Easy access tank and pump



Stability

Adjustable, anti-vibration feet





Working comfort

- Blocking of the shaft for wheel change
- Tool-less cut-off wheel change
- Motorized Y & Z cutting axes
- Motorization of the positioning axis X (optional)
- Light integrated into the hood:
 - Anti-glare
 - Optimal lighting of the working area
- Guided evacuation system for residual drops
- Concealed screws for easy cleaning
- Grid allowing to retain parts and large debris

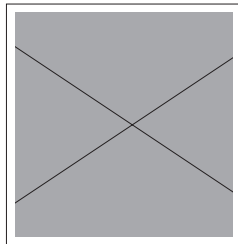

6 points lubrication close to the cut area

- Wheel guard including 6 lubrication points

Safety

- Two-hand control



- Braked stopping of the cut-off wheel
- Mechanical locking of the hood during operation
- Zero speed control before unlocking
- Emergency stop button
- CE marking

MECATOME T215

↕ 540mm closed lid
1 010mm open lid

↔ 840mm

↗ 860mm

📦 135kg

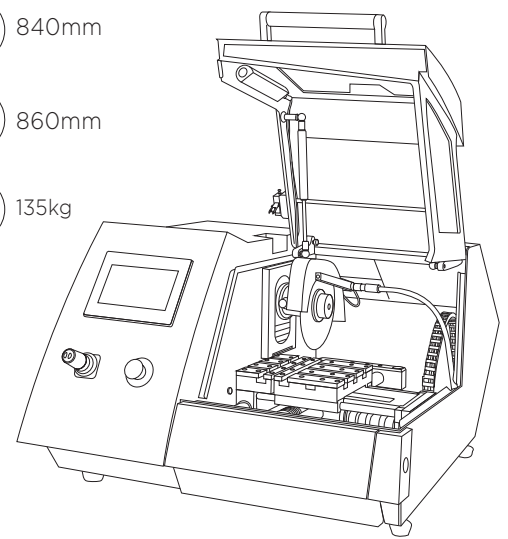

CUTTING ENVELOPE*

- Ⓩ = 60mm
- Ⓨ = 250mm
- Ⓧ = Option: 100mm
- ⓐ = 40mm (cut-off wheel Ø200mm)
- Ⓞ = Ø55mm
- = 55 x 190mm

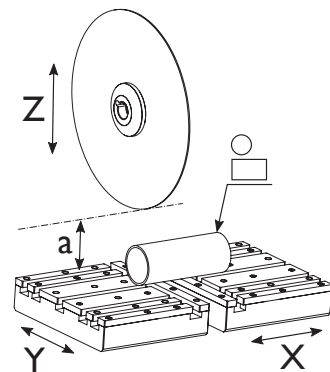

* This illustration of the cutting envelope is to show the maximum theoretical capacity only. The actual capacity may be increased, depending on sample material, cutting frequency and selected flanges.

CUTTING METHODS

Driven in assisted mode or in different programmable automatic modes, the MECATOME T215 is suitable for developing cutting methods as well as for routine use according to pre-established protocols. With an optional X-axis motorized table, the MECATOME T215 allows you to position the parts precisely and to achieve serial cuts. Both cutting axes can be driven separately or combined, depending on the need.

ASSISTED MODE

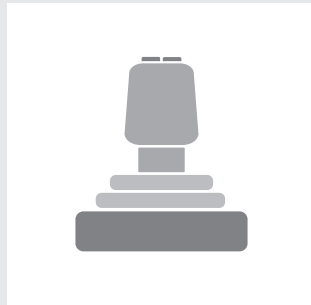

In this mode, the user directly controls the table feed using the joystick and defines the maximum speed and the regulation if necessary. This is an effortless manual cut.

PULSE MODE Y

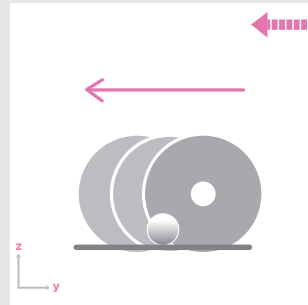

Cutting mode where the wheel advances intermittently along the Y axis. Dedicated to difficult materials or massive parts, this mode allows gradual release of the constraints and limits temperature peaks.

PULSE MODE Z

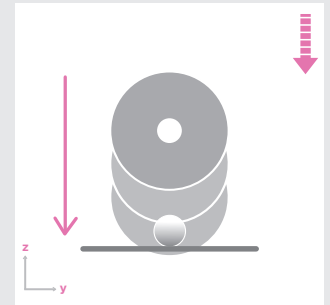

Cutting mode where the wheel advances intermittently along the Z axis. Dedicated to difficult materials or massive parts, this mode allows gradual release of the constraints and limits temperature peaks.

COMBINED MODE

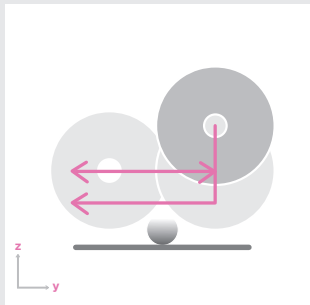

Cutting mode allowing a Z then Y cut, regulated or not. This mode increases the cutting capacity of the machine. The MULTI-COMBINED work mode allows the cut to be broken down into several stages along the Z axis. This mode is particularly dedicated to thick parts.

PROGRESSIVE COMBINED MODE

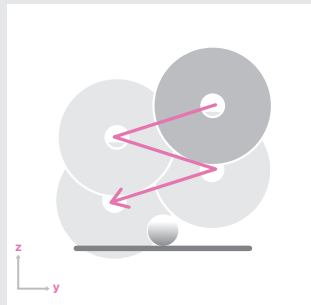

Cutting mode allowing a progression of the cut both along the Z axis and the Y axis, regulated or not. This mode optimizes the cutting time.

OSCILLATING MODE

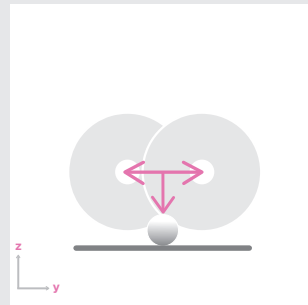

Z cutting mode, oscillating along the Y axis regulated or not. This mode is particularly dedicated to difficult to cut materials, lubrication of the cutting area is greatly improved.

EXPERT MODE

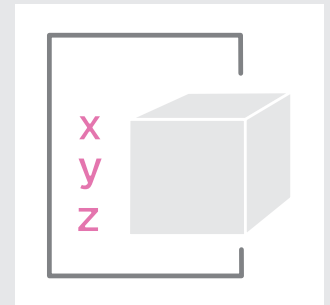

Operating mode that transforms your machine into a numerical control center, dedicated to cutting. This mode is compatible with the program mode.

OPTIONS



TRANSVERSAL TABLE WITH MOTORIZED MOVEMENT

Travel distance 100mm; 1/100th precision

- Position the parts
 - Carry out serial cuts
- Ref. 51461

25L RECIRCULATING TANK

Double filtration system: mechanical, optional magnetic
Ref. 51462



POSITIONING LASER

Visualize the cutting line
Ref. 51463



SUCTION & EXTRACTION

Mist extraction with fluid recovery
Ref. 51464

CHARACTERISTICS MEGATOME T215

HOOD

Type	Metal Frame & PETG Stainless steel cutting chamber
Safety	Two-hand control for table positioning, when hood open Mechanical locking of the hood during cutting Braked stopping of the cut-off wheel Zero speed check before unlocking the hood
Fumes extraction	Option: mist extraction with fluid recovery

MOTORISATION - POWER SUPPLY

Nominal power S1	1500W
Nominal power S2	2200W
Nominal power S3	2700W
Motor	Asynchronous motor controlled by frequency inverter
Power supply	230V - Single phase - 50/60Hz

CUT-OFF WHEEL

Kind of the cut-off wheel	Resinoid & Metallic
Size of the cut-off wheel	from Ø75 to Ø200mm
Rotation speed	from 300 to 6000 RPM
Arbor size	12,7mm

CONTROL

Control interface	Touchscreen 3-dimensional joystick with 2 shortcut buttons
Security access	Can be activated
Programmability	Up to 100 programs, password protected

CUTTING

Operating mode	Assisted, Automatic, Program Mode
Cutting modes	Regulated, Pulse Cutting, Combined, Oscillating
table automation	Y-axis movement
Cutting control	Feeding Regulation
Cutting axis	Motorized Y & Z axes (The X axis being a positioning axis)
Y axis travel	250 mm
Y axis speed	from 0,01 to 3mm/s
Z axis travel	60mm
Z axis speed	from 0,01 to 3mm/s
Serial cutting	Option: motorized x-axis table, travel distance 100mm
Table dimensions	Left table: 82 x 210mm Right table: 142 x 210mm
Distance between cut-off wheel and table	40mm (with Ø 200mm cut-off wheel)
Positioning laser	Option: Laser Class 1M; Po = 1mW; l = 635nm
Table type	Treated aluminum table, interchangeable stainless steel pallets
Holders	T-slotted table (12mm) accepting all commercial clamping systems

LUBRICATION - COOLING

Type of lubrication	By pump, flow rate 45L/min
Recirculation tank	Integrated - Capacity 10L Option: 25L external tank and pump
Type of filtration	Integrated: Grid & 100µm filter, optional magnetic filter External: Washable 100µm cloth filter, optional magnetic filter
Method of directing pumped coolant	6 lubrication points in the cut-off wheel guard

ERGONOMICS

Internal lighting	LED lighting integrated into the hood (IP 68)
Spray nozzle for cleaning	Quick connector, linked to main lubrication point
Cutting disc change	Tool-less cut-off wheel changing system
No-load sound level	< 70 dB

ACCESSORIES

STAINLESS STEEL VICES & CLAMPING SYSTEM



Cast in one piece quick clamping vice left
Ref. 51321



Cast in one piece quick clamping vice right
Ref. 51319

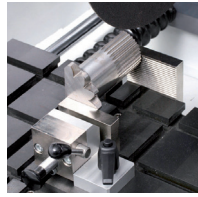

Quick clamping vice for long samples
Ref. 51356



Kopal clamp
Ref. 50616
Kopal kit
Ref. 50613

SAMPLE HOLDERS

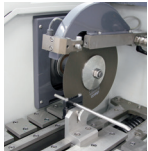

Sample chucks
(to use only with a motorized transversal table)
Ref. 51410



V shaped sample chuck
Ref. 51715



Vice chuck for longitudinal cuts
Ref. 51717



Orientable chuck (to be used with aluminium plates)
Ref. 51162 and 51163 - Ref. 51156

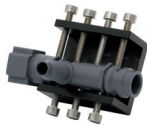

Irregular shaped sample chuck
Ref. 51716



Chuck for small samples (vice type)
Ref. 51713



Chuck for cylindrical sample
Ref. 51714

CONSUMABLES

RESINOID CUT-OFF WHEELS

	REF.	ABRASIVE	Ø
Ferrous materials			
AO	01046	Al ₂ O ₃	Ø 125 x 0,5 x 12,7mm
	01043	Al ₂ O ₃	Ø 150 x 0,5 x 12,7mm
	01002	Al ₂ O ₃	Ø 200 x 1,6 x 25,4mm*
A	01040	Al ₂ O ₃	Ø 100 x 0,3 x 12,7mm
	01001	Al ₂ O ₃	Ø 200 x 0,8 x 25,4mm*
Non-ferrous materials			
C MNF	01005	SiC	Ø 200 x 1,6 x 25,4mm*
	01041	SiC	Ø 100 x 0,3 x 12,7mm
Ferrous & non-ferrous materials			
UTW	01100	SiC	Ø 180 x 0,5 x 25,4mm*
	01101	SiC	Ø 200 x 0,5 x 25,4mm*
S	01060	SiC	Ø 180 x 0,5 x 25,4mm*

* to be used with reduction rings ref. 51324

METALLIC CUT-OFF WHEELS

	REF.	Ø
Hard ferrous materials		
CBN	02059	Ø 75 x 0,5 x 12,7mm
	02062	Ø 100 x 0,5 x 12,7mm
	02050	Ø 125 x 0,5 x 12,7mm
	02065	Ø 150 x 0,6 x 12,7mm
	02056	Ø 175 x 0,7 x 12,7mm
	02039	Ø 200 x 0,9 x 32mm*

* to be used with reduction rings ref. 51331

REDUCTION RINGS*

REF.	DESIGNATION	Ø
Pack of 5		
51324	Reduction ring aluminium	25,4 / 12,7mm
51331	Reduction ring aluminium	32 / 12,7mm
51332	Reduction ring aluminium	25,4 / 12,7mm

* Other diameters on request.

METALLIC CUT-OFF WHEELS

	REF.	Ø	
Ceramic & non-ferrous materials			
DIAMOND LR	02058	Ø 75 x 0,5 x 12,7mm	
	02033	Ø 100 x 0,5 x 12,7mm	
	02035	Ø 125 x 0,5 x 12,7mm	
	02037	Ø 150 x 0,6 x 12,7mm	
	02067	Ø 175 x 0,7 x 12,7mm	
	02041	Ø 200 x 0,9 x 32mm*	
	02030	Ø 75 x 0,3 x 12,7mm	
	DIAMOND LM	02031	Ø 100 x 0,3 x 12,7mm
		02034	Ø 125 x 0,5 x 12,7mm
		02036	Ø 150 x 0,6 x 12,7mm
02055		Ø 175 x 0,7 x 12,7mm	
02038		Ø 200 x 0,9 x 32mm*	
02057		Ø 75 x 0,3 x 12,7mm	
DIAMOND LM+		02060	Ø 100 x 0,3 x 12,7mm
		02063	Ø 125 x 0,5 x 12,7mm
	02064	Ø 150 x 0,6 x 12,7mm	
	02066	Ø 175 x 0,7 x 12,7mm	
	02040	Ø 200 x 0,9 x 32mm*	
	Composit & plastic materials		
DIAMOND ELD	02100	Ø 100 x 1,4 x 12,7mm	
	02101	Ø 125 x 1,4 x 12,7mm	
	02102	Ø 150 x 1,4 x 12,7mm	
	02103	Ø 175 x 1,4 x 12,7mm	
	02104	Ø 200 x 1,4 x 12,7mm	

* to be used with reduction rings ref. 51331

OTHER ACCESSOIRES



Base cabinet for automatic cutting machine (large model)
Ref. 51470

ANTIRUST COOLANT

REF.	DESIGNATION
01025	1L bottle
01090	5L drum
01026	10L drum

ANTIFOAM AGENT

REF.	DESIGNATION
01094	1L bottle
01095	5L drum
01096	10L drum

ANTISEPTIC LIQUID

REF.	DESIGNATION
01093	500CC bottle
01097	1L bottle
01098	5L drum